

### Galvanised Box Fan 50" 02382806



#### Technical data

Voltage	U	230/400	V
Phase		3	~
Frequency		50	Hz
Speed		570	RPM
Power consumption	Pe	1600	W
Nominal current	I	5/2.9	A
Maximum current	I	5.3/3.1	A
Capacitor	I	-	µF
Ambient temperature	Tamb min/max	-25...40	°C
Insulation Class		CLF	
IP Class Fan		IP55	
Weight		75.6	kg

#### Fan details

Impeller blades	3
Impeller type	10
Impeller system	N
Impeller material	PG

#### Control options

Triac controller	No
Transformer	No
Frequency drive	No
Intelligent Fan Drive	No

#### Dimensions

A01	1284 mm
A09	275 mm
A12	96 mm
A19	1382 mm
A21	1382 mm
A22	523 mm
A31	85 mm

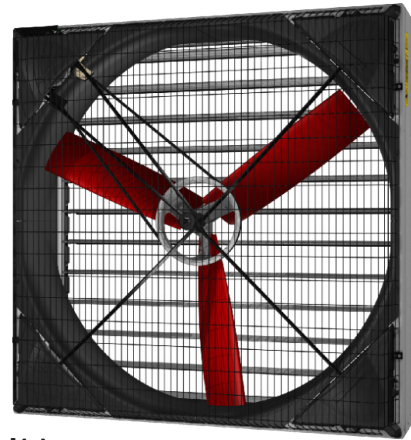
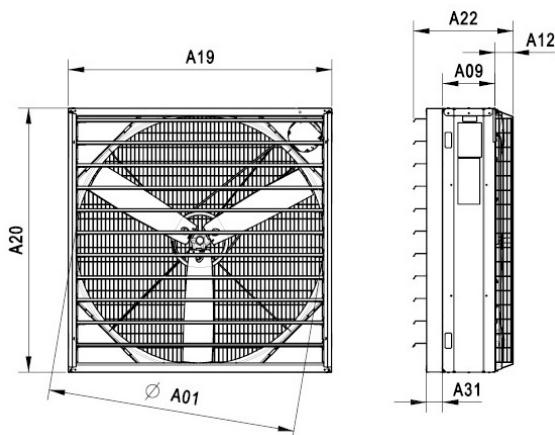

#### Approval(s)



No. 12127

#### Wiring diagram - Fan

AF01 - CCW

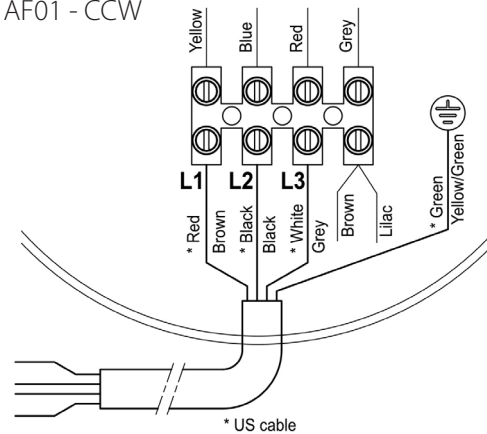

#### Characteristics

0 Pa 45900 m<sup>3</sup>/h  
50 Pa 33700 m<sup>3</sup>/h

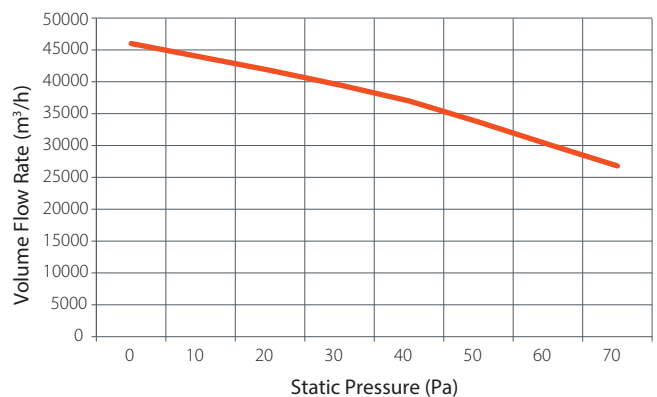

Feeding



Drinking



Climate



Housing

Maagan Michael, D.N. Menashe, 3780500, Israel

Tel: +972-73-2413001, Fax: +972-73-2333711

info@plassonlivestock.com | www.plassonlivestock.com