

Galvanised Box Fan 50" 02382829

Technical data

Voltage	U	240/420	V
Phase		3	~
Frequency		60	Hz
Speed		570	RPM
Power consumption	Pe	1650	W
Nominal current	I	4.7/2.7	A
Maximum current	I	5.0/2.9	A
Capacitor	I	-	µF
Ambient temperature	Tamb min/max	-25...40	°C
Insulation Class		CLF	
IP Class Fan		IP55	
Weight		75.6	kg

Fan details

Impeller blades	3
Impeller type	10
Impeller system	N
Impeller material	PG

Control options

Triac controller	No
Transformer	No
Frequency drive	No
Intelligent Fan Drive	No

Dimensions

A01	1284 mm
A09	275 mm
A12	96 mm
A19	1382 mm
A21	1382 mm
A22	523 mm
A31	85 mm

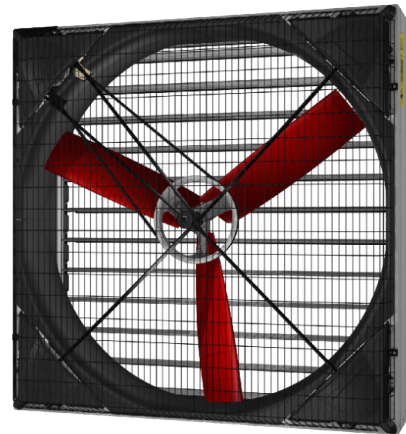
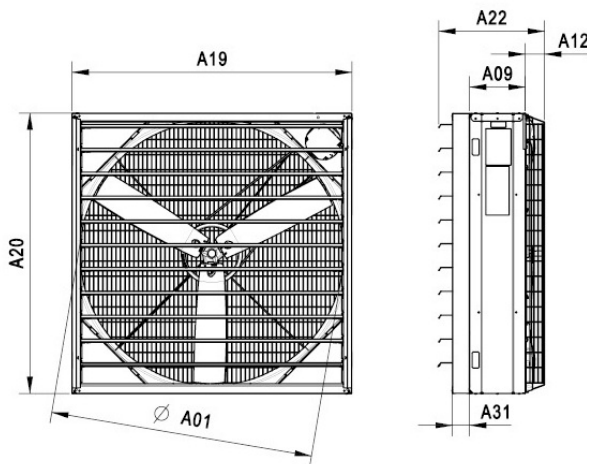

Approval(s)



No. 05078

Wiring diagram - Fan

AF01 - CCW

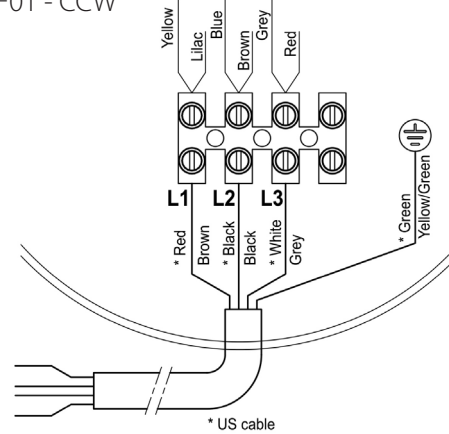

Characteristics

0 Pa 45300 m³/h
 50 Pa 33600 m³/h

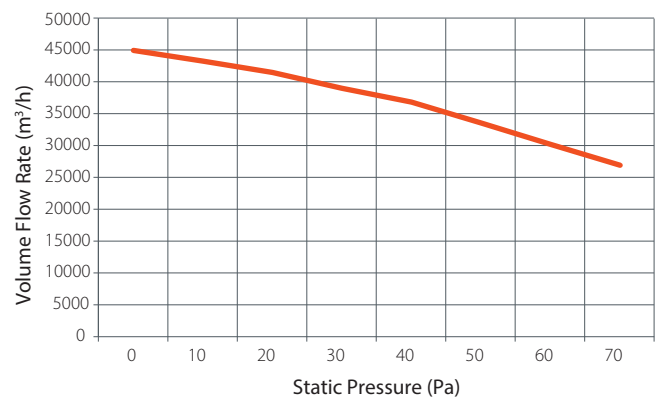

Feeding



Drinking



Climate



Housing

Maagan Michael, D.N. Menashe, 3780500, Israel

Tel: +972-73-2413001, Fax: +972-73-2333711

info@plassonlivestock.com | www.plassonlivestock.com