

### Galvanised Box Fan 54" 02382833



#### Technical data

Voltage	U	230/400	V
Phase		3	~
Frequency		60	Hz
Speed		585	RPM
Power consumption	Pe	1850	W
Nominal current	I	5.6/3.2	A
Maximum current	I	6.3/3.7	A
Capacitor	I	-	µF
Ambient temperature	Tamb min/max	-25...40	°C
Insulation Class		CLF	
IP Class Fan		IP55	
Sound pressure level at 2 m	Lp	74	dB(A)
Weight		84.4	kg

#### Fan details

Impeller blades	3
Impeller type	12
Impeller system	B
Impeller material	PG

#### Control options

Triac controller	No
Transformer	No
Frequency drive	No
Intelligent Fan Drive	No

#### Dimensions

A01	1375 mm
A09	295 mm
A12	96 mm
A19	1480 mm
A20	1480 mm
A22	548 mm
A31	85 mm

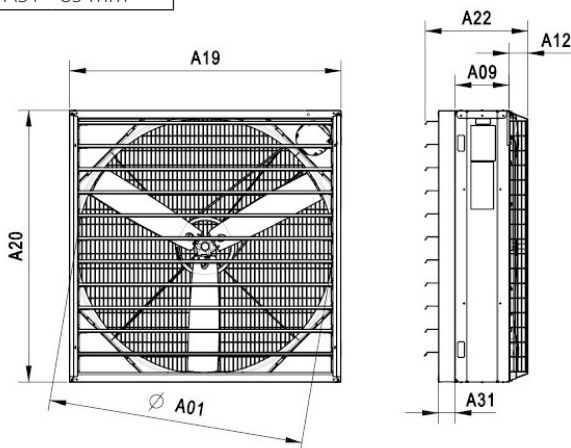

#### Approval(s)



#### Wiring diagram - Fan

AB01 - CCW

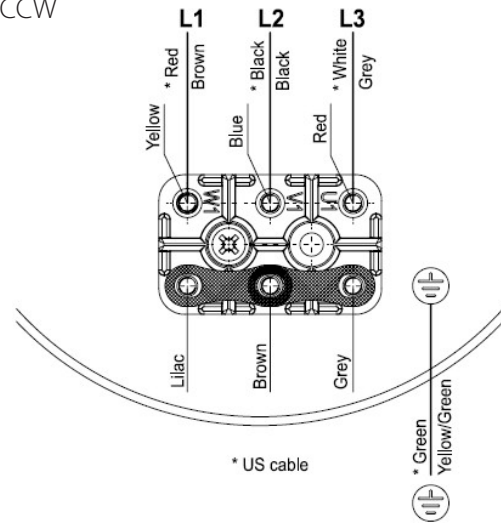

#### Characteristics

0 Pa 51100 m³/h  
50 Pa 40700 m³/h

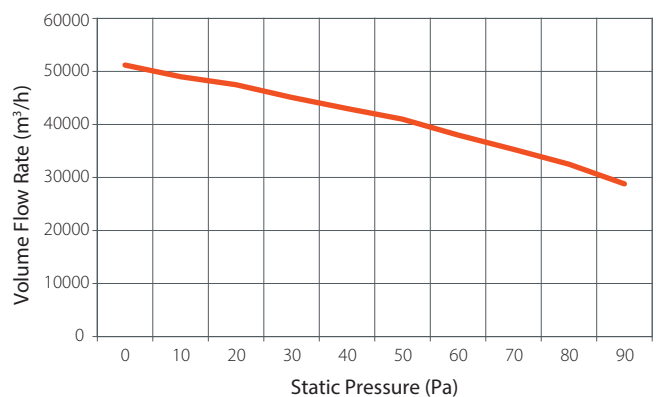

Maagan Michael, D.N. Menashe, 3780500, Israel

Tel: +972-73-2413001, Fax: +972-73-2333711

info@plassonlivestock.com | www.plassonlivestock.com