

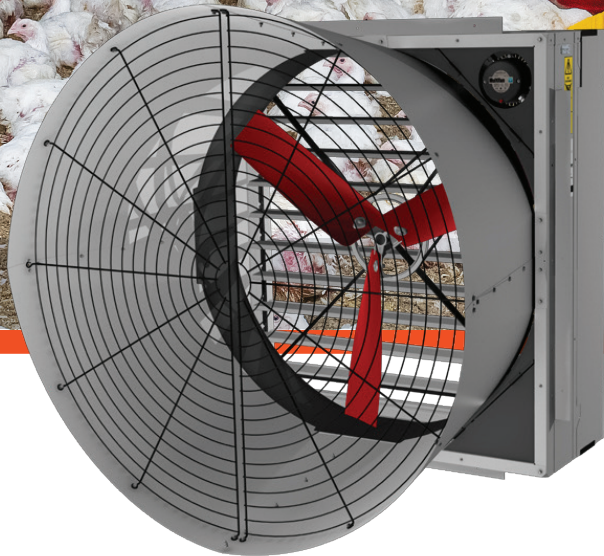

Exhaust Fans



Global Presence - Local Commitment



Feeding



Drinking



Climate



Housing



Exhaust Fans

Compact and flexible

With the extensive program of Exhaust Fans, we offer a wide range of efficient fans for livestock houses. The products are characterized by their compact design and available in various dimensions and motors. This is why these fans are an adequate all-round solution for each ventilation demand. The aerodynamic design assures effective and efficient ventilation. Depending of your need or local situation, our Exhaust Fan offers the solution for minimum ventilation, higher-pressure applications or high air volumes.

Energy efficient

- Aerodynamic design for low air resistance
- Ready for ErP2015 or 2020
- Interconnected louvers for uniform opening
- Energy efficient IE2 or IE3 motors

Reliable

- Materials with high resistant against corrosive climates
- Water and dust resistant (IP55)
- Maintenance free V-belt for 50" Box Fan
- Maintenance free V-belt and belt tensioner for 54" Box Fan
- Abrasion resistant aluminum blade-pulley
- Blades made of durable polypropylene & fiberglass
- Resistant against UV-radiation

Options

- Available in 36", 50" and 54"
- Multiple blades for higher pressure applications
- Motors for single / three phase, 50Hz/60Hz and different voltages
- Various shutter and wire guard options
- Galvanized Box and Cone Fan for higher air volumes



PLASSON products are well-known for consistent high quality, durability and longevity with worldwide availability. Our motors are optimal motor-impeller combination ensure energy efficient and high performance fans.

We can offer you several options so you can benefit optimally from your own situation and achieve the best possible production results.

One of these options is adding a cone to the fan. Using a cone gives a decrease of the air resistance, allowing the fan an increase of 10% in air volume.

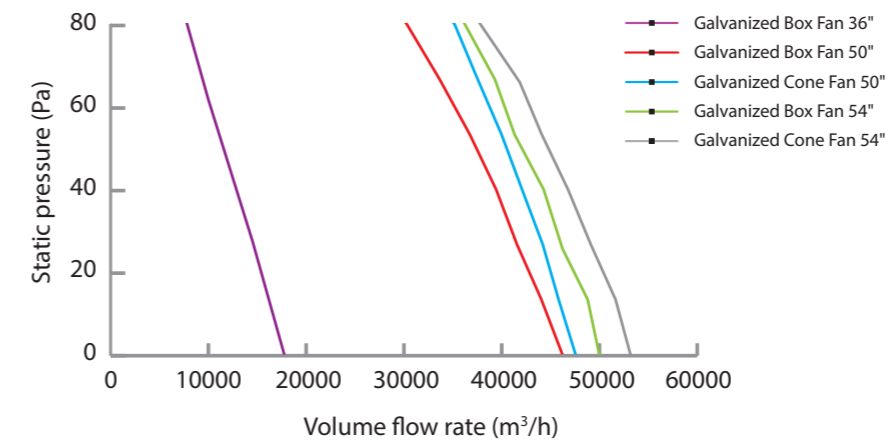

ITEM #	SIZE	Type	Hz
02382804	36"	BOX	50Hz
02382827			60Hz
02382806	50"	BOX	50Hz
02382829			60Hz
02382808	50"	CONE	50Hz
02382831			60Hz
02382810	54"	BOX	50Hz
02382833			60Hz
02382812	54"	CONE	50Hz
02382835			60Hz
02382837		Cone Butterfly	60Hz

Dimensions

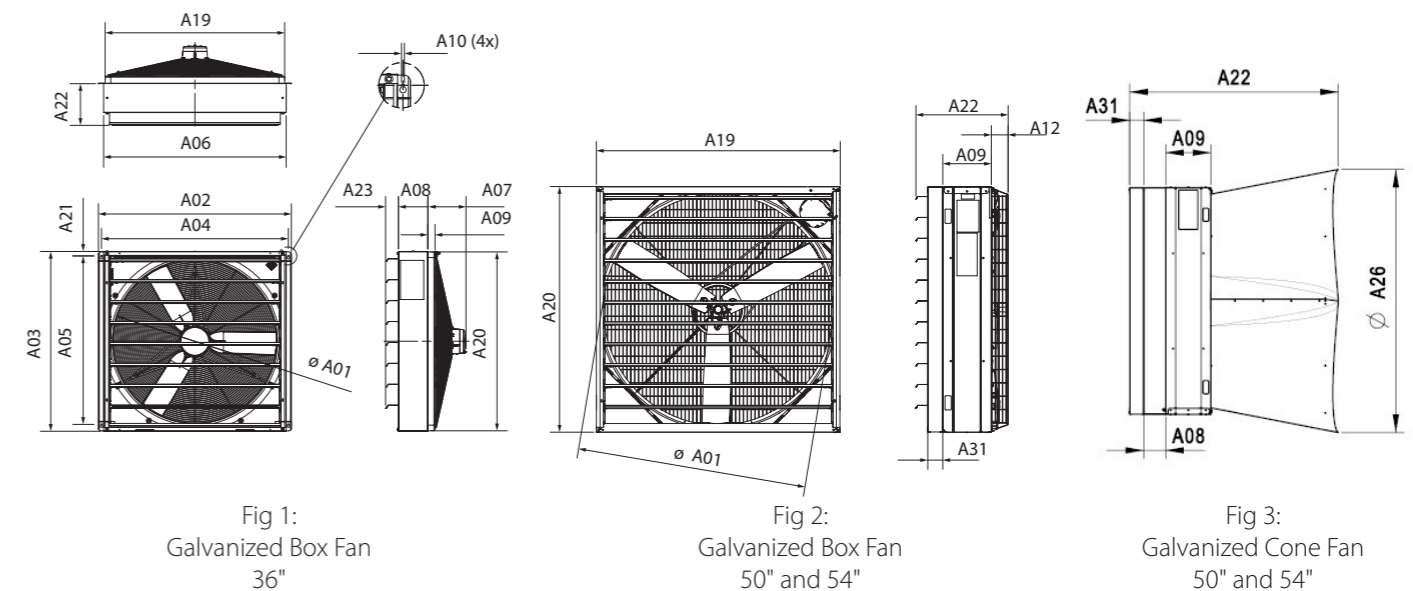
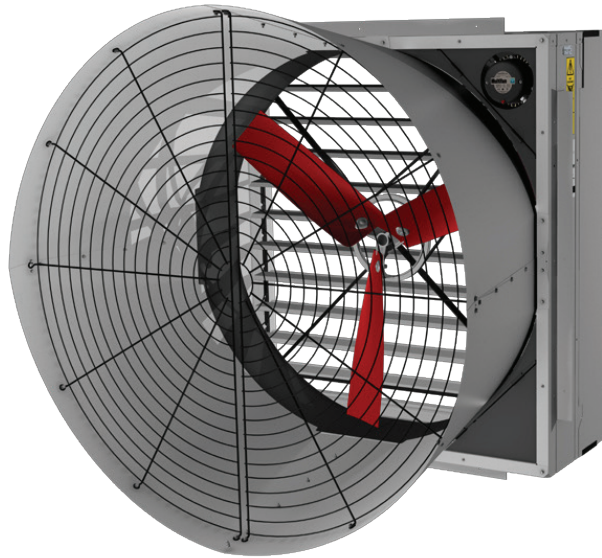

Figure	Type	A01	A02	A03	A04	A05	A06	A07	A08	A09	A10	A12	A19	A20	A21	A22	A23	A26	A31
1	Galvanized Box Fan 36" ON/OFF	915	1080	1014	1046	947	1022	214*	165	40	6,5		1005	1005	25	234	72		
2	Galvanized Box Fan 50"	1284								275		96	1382	1382		523			85
3	Galvanized Box Fan 54"	1375								295		96	1480	1480		548			85
4	Galvanized Cone Fan 50"	1284							135	275			1382	1382		1275		1600	85
5	Galvanized Cone Fan 54" & Btrfly	1375							168	295			1480	1480		1356		1660	85

* The Galvanized Box Fan 36" is also available with a controllable motor, A07 = 265 mm

** Dimensions are in mm



Ventilation



Cooling



Fogging



Heating



Lighting



Control



Feeding



Drinking



Climate



Housing

Maagan Michael, D.N. Menashe, 3780500, Israel | Tel: +972-73-2413001, Fax: +972-73-2333711
info@plassonlivestock.com | www.plassonlivestock.com